

# DUGGAN



DUGGAN PROFILES & STEEL SERVICE CENTRE Ltd.

Issue 1 - September 2009

## GUTTERS, FLASHINGS AND ACCESSORIES



## THE COMPLETE SOLUTION FOR YOUR FARM BUILDING

**DUGGAN**  
A STEEL GROUP Company

# CONTENTS



Introduction 3



Bevel Gutters 4



Box Gutters 6



Half-Round Gutters 6



Downpipes & Accessories 7



HiLine Gutters 8



Cleats and Plates 9



Flashings 10



*As a leading player in the supply of steel building components to the agricultural sector Duggan Profiles are anxious to provide customers with products best suited to their needs and which utilise best available material and technological advancements. To this end the company is pleased to announce additions to its already extensive ancillary product range which we are confident will be of interest to contractor and end user alike.*

*Substantial investment in manufacturing capability now means the company can offer selected rainwater goods in materials similar to those used for approved cladding profiles. This investment also allows downpipes and downpipe ancillaries to be provided with standards of fit and watertightness which to date have been difficult to achieve with these traditionally "handmade" components. Through the use of this extended product range colour matching of ancillary components to external cladding is now more easily achievable for situations where same is a stated end user preference.*

*This brochure is intended to illustrate the scope of the extended and revised range of Duggan Profiles ancillary components for farm buildings allowing interested parties choose from traditional time proven designs combined with the best available manufacturing and material options. We are confident that this choice, when combined with the levels of service traditionally associated with the company, will allow our customers make an assured and informed choice.*

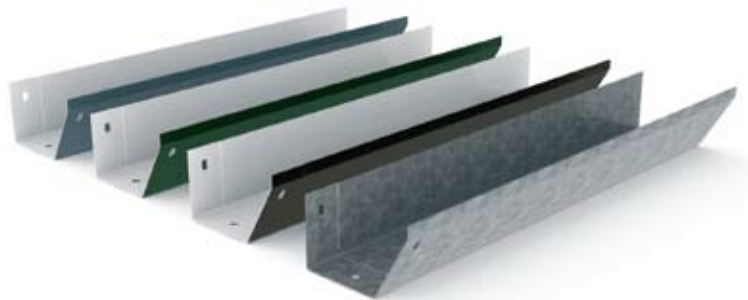

# BEVEL GUTTERS

## Available Material options

- 450g Galvanised Mild Steel
- Pre-painted Steel in both Juniper Green and Slate Grey.

## Types

- Standard and Self Hanging Bevel Gutter options are available. The latter is self supporting and does not require brackets for mounting.

## Lengths/Sizes Available

- 100mm (4") & 150mm (6") base widths are available in 4.876m (16') lengths in both Standard and Self Hanging.

## Mid Drops/End Drops/Outlets

- Bevel Mid Drops are available ex stock with either 100(4") or 75mm(3") outlets to suit the Bevel Gutter range. These can also be used as End Drops with the addition of the appropriate Bevel Stopend (supplied separately). Bolt-in Galvanised Plate Outlets are available in either 100(4") or 75mm(3").

## Stopends

- Stopends are available to match the size and colour of Gutter in question.

## 90° Bevel Angles

- These are used to maintain continuity where the run of gutter changes direction e.g. a hipped roof building. Both External and Internal Bevel Angles are available to suit our range of Bevel Gutters.

## Mounting Brackets

- These are manufactured from 30 x 5mm mild steel and galvanized after manufacture. They are available in a variety of types and sizes as outlined below to suit a variety of applications.

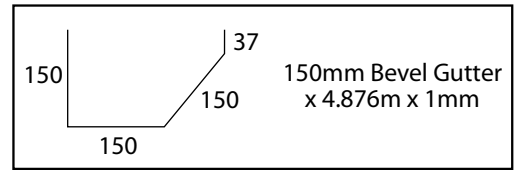
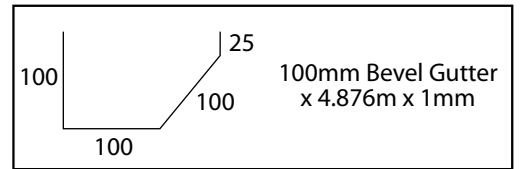

100 or 150mm  
Self-hanging Gutters  
4.876m 15° S/Hang.

100 or 150mm  
Bevel Gutter 4.876m

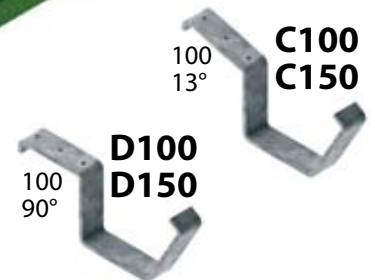

100 or 150mm **C** Bevel Gutter Bracket  
100 or 150mm **D** Bevel Gutter Bracket

100 or 150mm  
Bevel Angle Internal

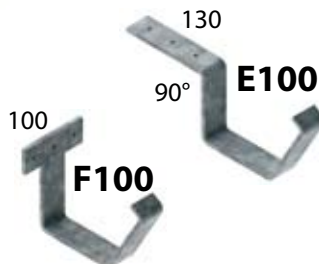

100mm **E** Bevel Gutter Bracket  
100mm **F** Bevel Gutter Bracket 100 Wall

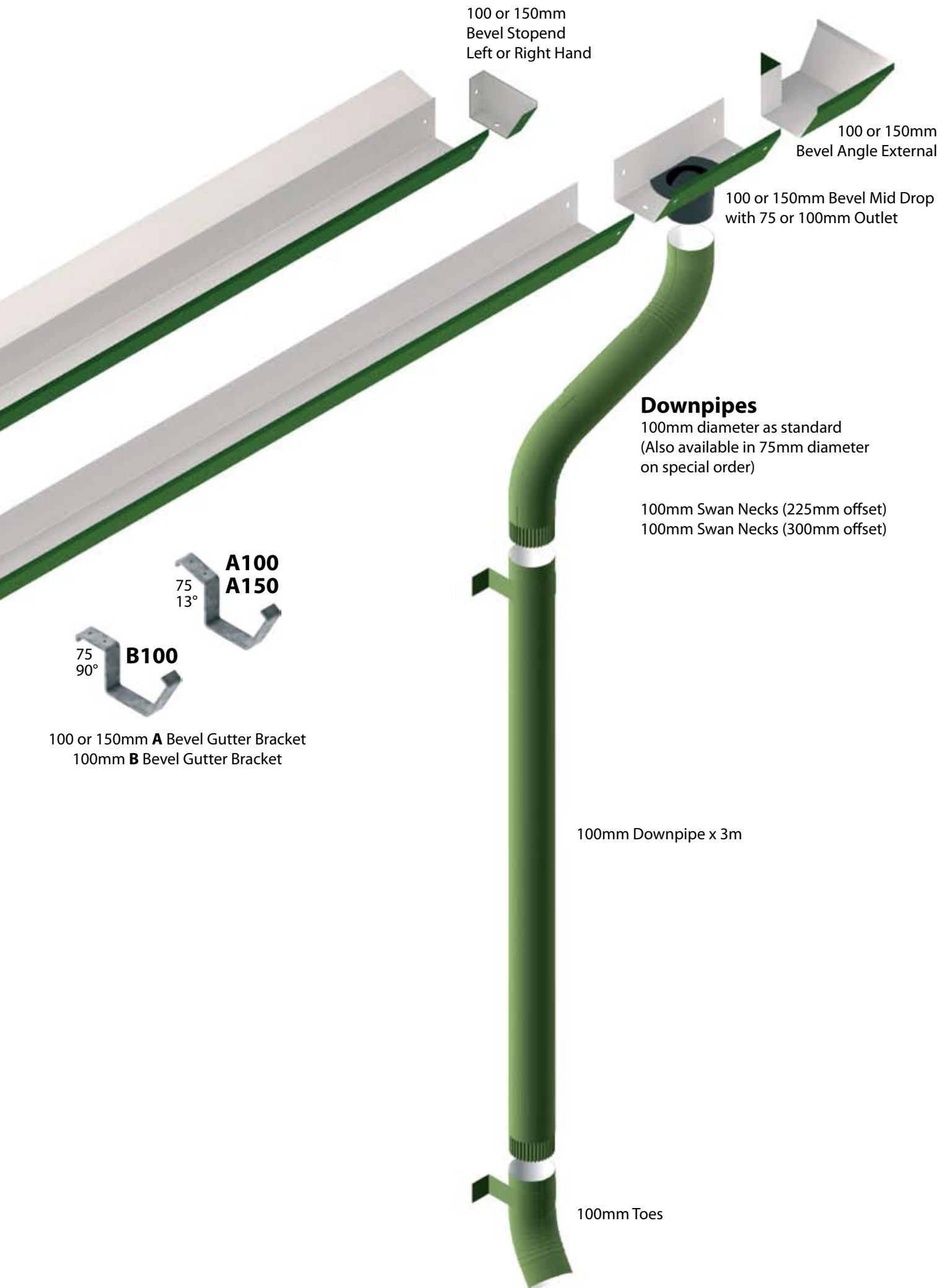

100 or 150mm  
Bevel Stopend  
Left or Right Hand

100 or 150mm  
Bevel Angle External

100 or 150mm Bevel Mid Drop  
with 75 or 100mm Outlet

### Downpipes

100mm diameter as standard  
(Also available in 75mm diameter  
on special order)

100mm Swan Necks (225mm offset)  
100mm Swan Necks (300mm offset)

75  
13°  
**A100**  
**A150**

75  
90°  
**B100**

100 or 150mm **A** Bevel Gutter Bracket  
100mm **B** Bevel Gutter Bracket

100mm Downpipe x 3m

100mm Toes

# BOX GUTTERS

## Available Material options

- 450g Galvanised Mild Steel
- Pre-painted Steel in both Juniper Green and Slate Grey.

## Lengths/Sizes Available

- Box Gutters are manufactured with a 150mm (6") wide base. They are supplied in 4.876m (16') lengths.

## Mid Drops/End Drops/Outlets

- Box Mid Drops are available ex stock with either 100(4") or 75mm(3") outlets. These can also be used as End Drops with the addition of the appropriate Box Gutter Stopend (supplied separately). Bolt-in Galvanised Plate Outlets are available in either 100(4") or 75mm(3").

## Stopends

- Box Stopends are available ex stock to match the colour of Gutter in question.

## 90° Box Angles

- These are used to maintain continuity where the run of gutter changes direction e.g. on a hipped roof building. Due to the symmetrical shape of the Box Gutter the same Box Angle will suit both External and Internal applications.

## Mounting Brackets

- These are manufactured from 30 x 5mm mild steel and galvanized after manufacture. They are available in a variety of types as outlined below to suit the application in question.

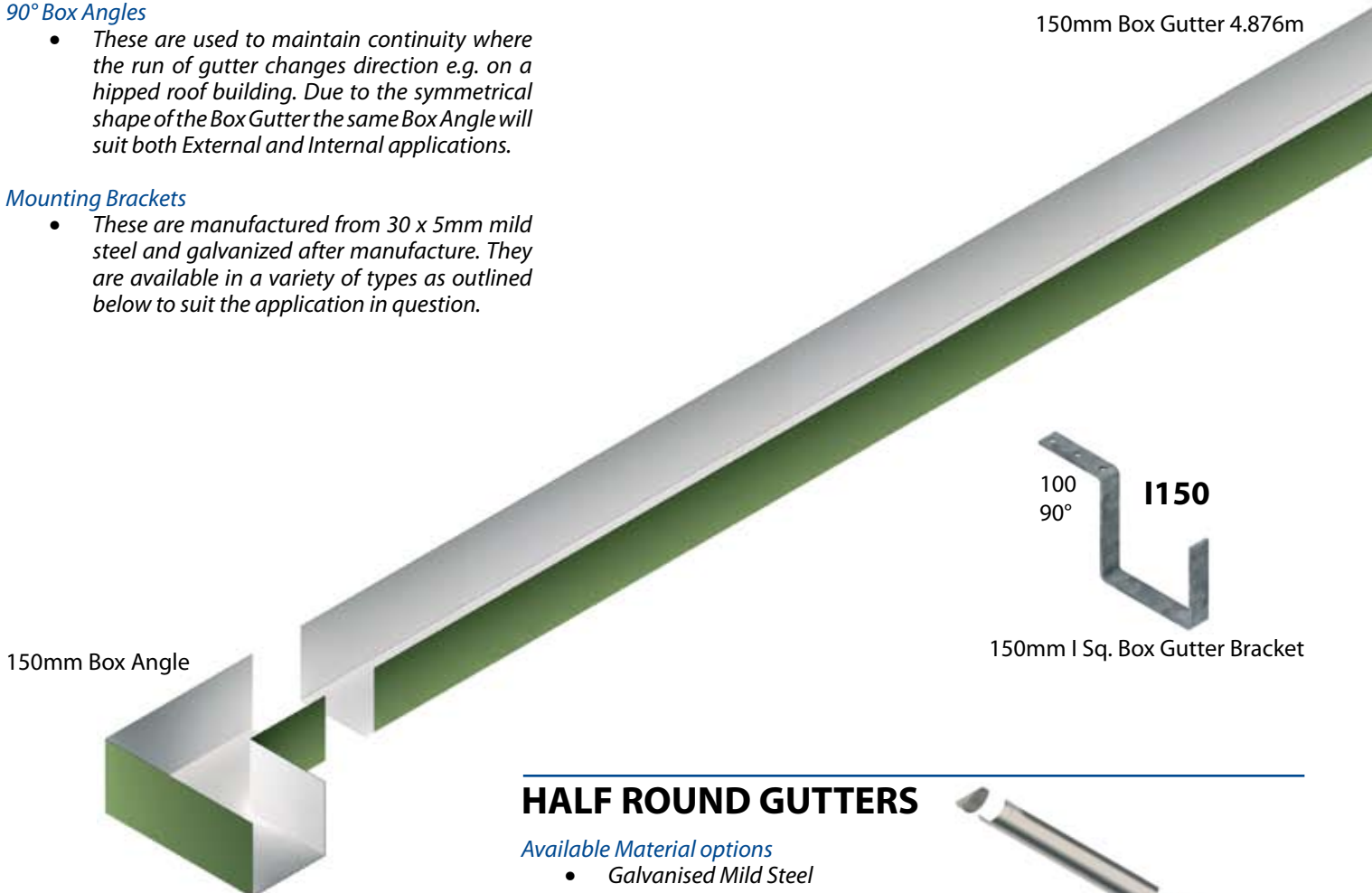
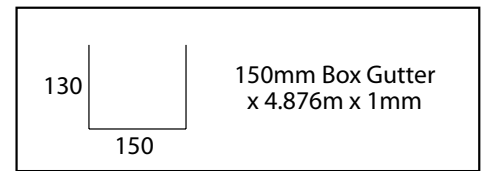

# HALF ROUND GUTTERS

## Available Material options

- Galvanised Mild Steel

## Lengths/Sizes Available

- Half Rounds may be supplied in either 5" or 6".
- The standard length is 6'.
- Stopends, Mid Drops, End Drops, 90° Half Round Angles, galvanised mild steel mounting brackets are available with 3" Outlets to suit both 5 and 6" Half Round Gutters.

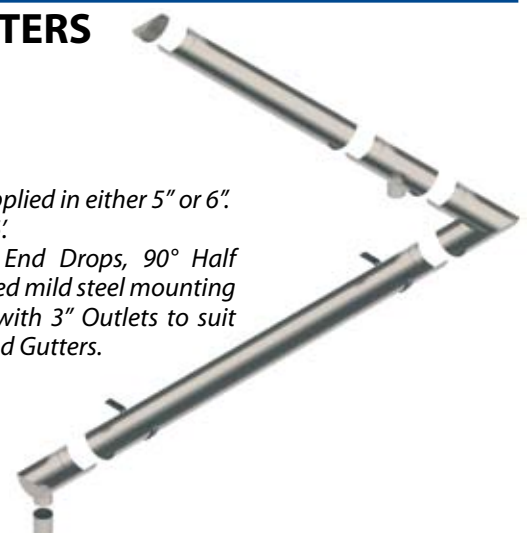

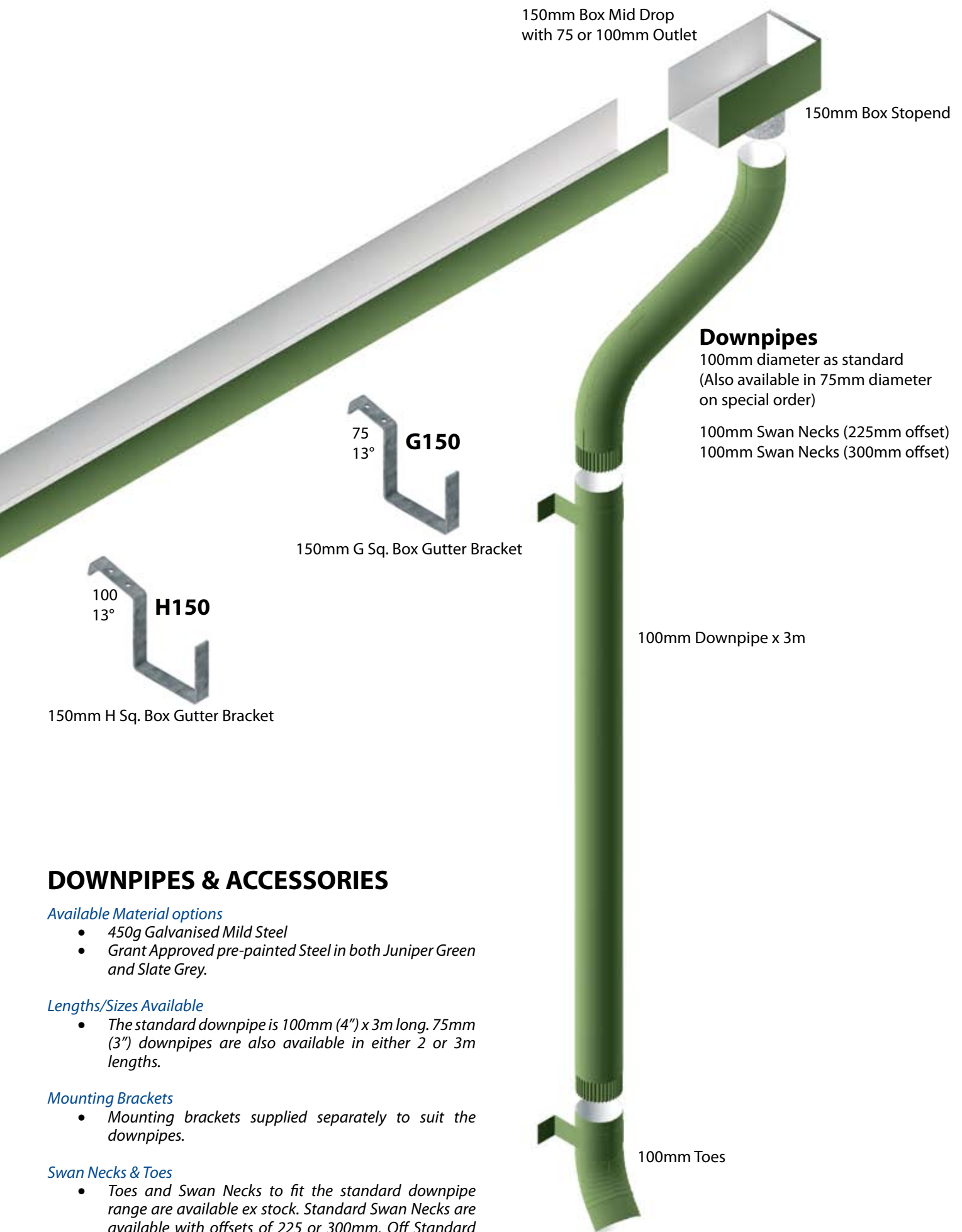

## DOWNPIPES & ACCESSORIES

### Available Material options

- 450g Galvanised Mild Steel
- Grant Approved pre-painted Steel in both Juniper Green and Slate Grey.

### Lengths/Sizes Available

- The standard downpipe is 100mm (4") x 3m long. 75mm (3") downpipes are also available in either 2 or 3m lengths.

### Mounting Brackets

- Mounting brackets supplied separately to suit the downpipes.

### Swan Necks & Toes

- Toes and Swan Necks to fit the standard downpipe range are available ex stock. Standard Swan Necks are available with offsets of 225 or 300mm. Off Standard Swan Necks with custom offsets can also be produced to customer requirements.

### Outlets

- Galvanized Bolt-in Outlets are available in either 100 or 75mm diameter.

# HILINE GUTTERS

These Gutters and their associated ancillaries are bespoke items manufactured to order to suit the individual application. They are hung off the tail of the roof sheeting and are more commonly used with box type profiles. Profiled brackets suspended off the roof are used to help support the gutter.

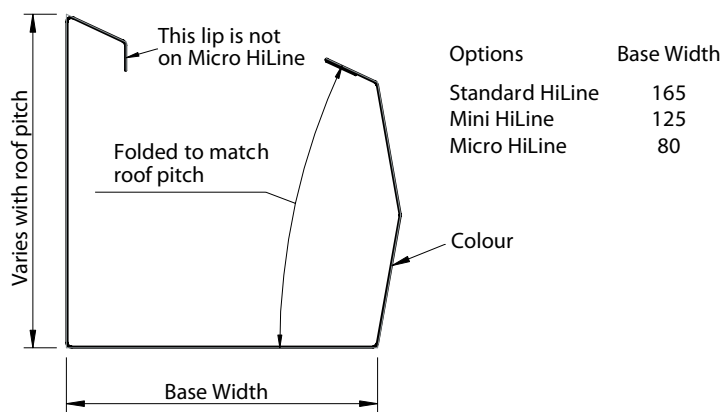

## Available Material options

HiLine Gutters are generally made to match or contrast with the predominant colour of the building and are typically supplied in the following materials.

- Grant Approved painted Mild Steel in both Juniper Green and Slate Grey.
- PVC coated and galvanized mild steel, this is available in a wide range of colours to match that of the sheeting used.

## Lengths/Sizes Available

HiLine Gutters can be folded to suit any roof pitch and are typically supplied in 6m lengths approx. The standard girth is 625mm with a base width of 165mm.

## Mid Drops/End Drops/Outlets

- Bolt-in Galvanised Plate Outlets are available in either 100(4") or 75mm(3"). These are supplied loose for fitting on site.

## Stopends

- Stopends are made to match the profile and colour of Gutter, they are not stock items and should be ordered with the gutter.

## HiLine Angles

- These can be factory fabricated to suit the individual application in question.

## Mounting Brackets

- 600mm long folded support straps are suspended off the roof sheeting and used to help support the Gutter. These must be made to fit the corrugation of the sheeting and are typically manufactured from 0.7mm mild steel in the same colour and finish as the roof sheeting. They are typically required at 1m centre's.

# CUSTOMISED GUTTERS & PRESSINGS

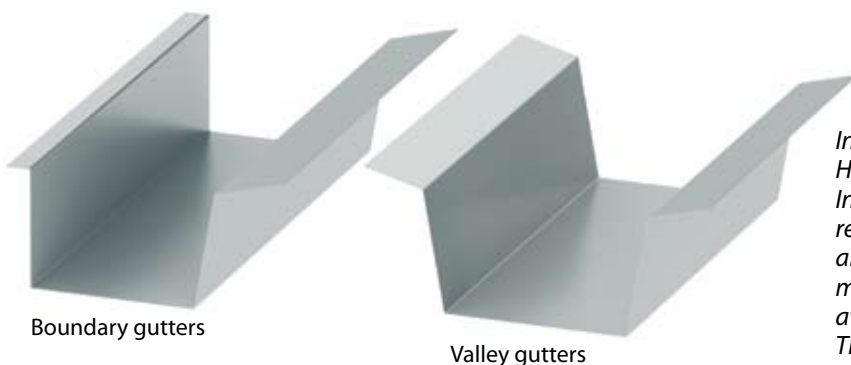

In certain applications use of the standard Bevel, Box or Half Round systems may not be possible or appropriate. In such cases bespoke profiles may be folded to customer requirements. The maximum available length is 8m and any of the materials used for our standard gutter ranges may be used. In addition PVC membrane lined steel is also available for maximum corrosion and leakage protection. The customer must supply dimensions of the required profile as well as details of the material and quantity involved.

Made to customer's specifications up to 8m in length

## CAP PLATES

190mm 2-hole 10mm Plate  
Holes are 18mm Ø

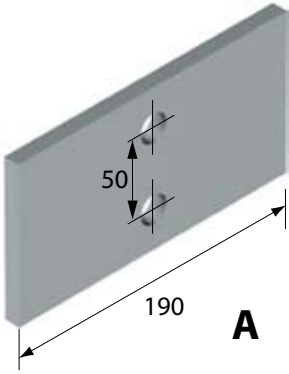

190mm 4-hole 10mm Plate  
Holes are 18mm Ø

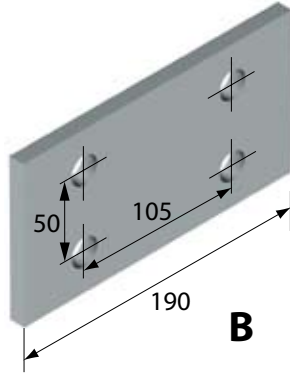

210mm 2-hole 10mm Plate  
Holes are 18mm Ø

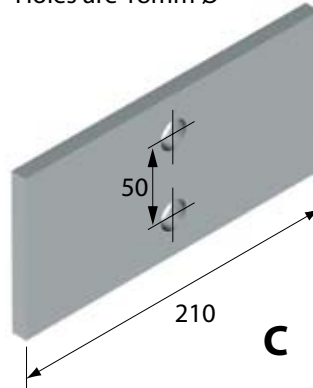

210mm 4-hole 10mm Plate  
Holes are 18mm Ø

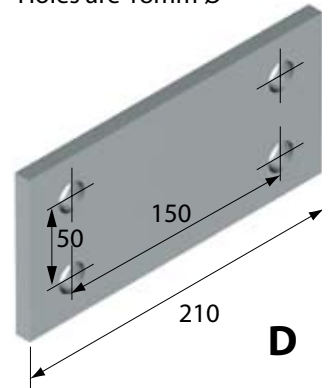

## TIMBER CLEATS

Centre Timber Cleat  
7mm Angle  
Holes are 18mm Ø

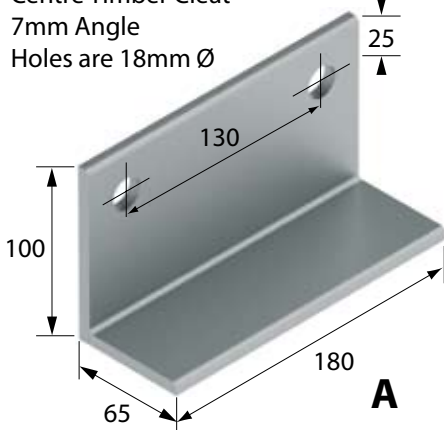

Gable Timber Cleat  
7mm Angle  
Holes are 18mm Ø

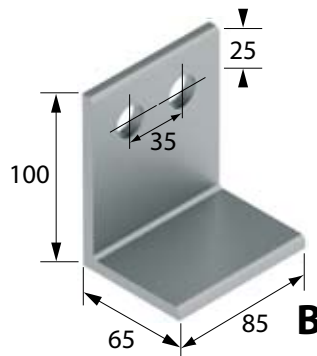

Side Sheeting Cleat  
7mm Angle  
Holes are 18mm Ø

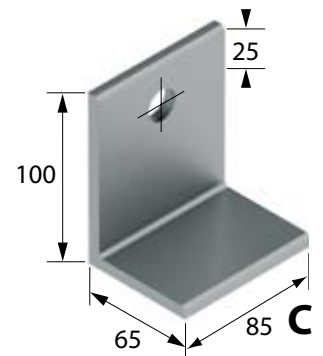

## BASE PLATES

200mm 4-hole 12mm Plate  
Holes are 22mm Ø

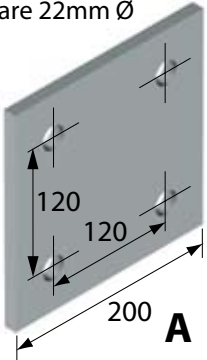

300mm 4-hole 12mm Plate  
Holes are 22mm Ø

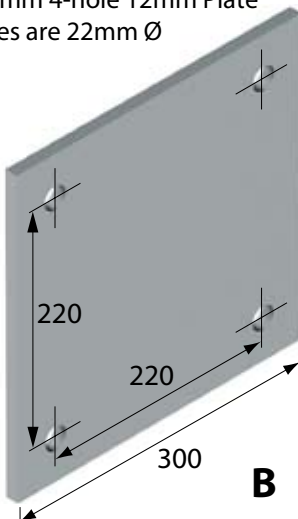

## RAISED CANOPY BRACKETS

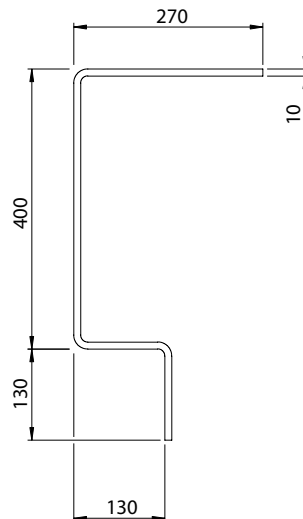

These brackets are used in conjunction with light gauge folded angle sections to provide continuous support for raised canopies on vented ridges. They are supplied pre-punched for bolting to roof purlins and are fitted as indicated below at 1500mm centres.

Material: 40 x 10mm galvanised Mild Steel

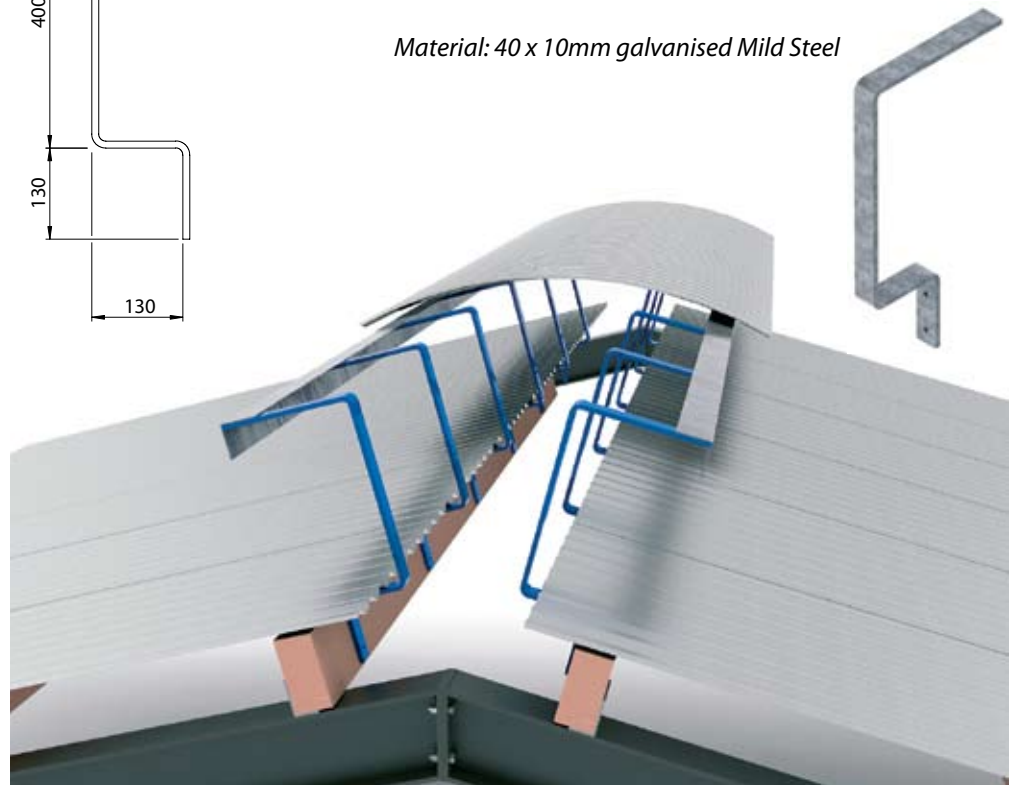

**STANDARD FLASHINGS** (Available from stock in Slate Grey, Juniper Green, Turf Brown and Galv.  
For Non-Standard Flashings, please contact our Sales Office)

Ridge Cap x 3m  
200x200mm Juniper Green

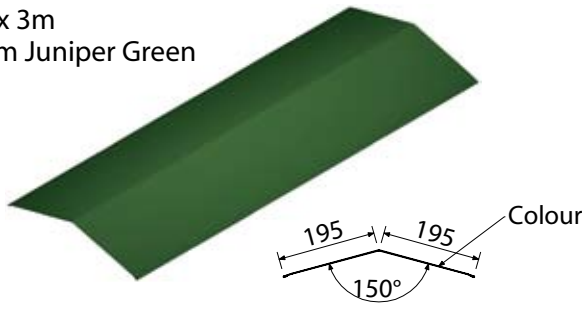

Barge Board x 3m  
115x135mm Juniper Green

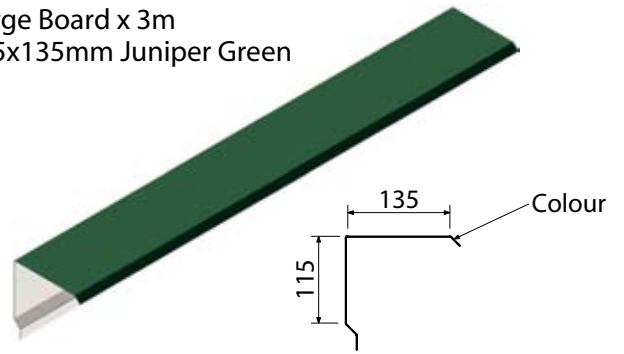

Ridge Cap x 3m  
300x300mm Juniper Green

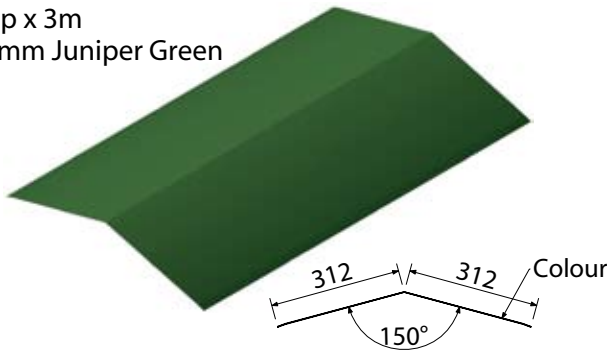

Corner Flashing x 3m  
150x150mm Juniper Green

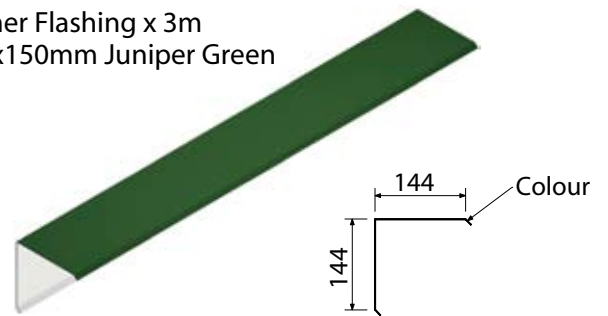

Drip Flashing x 3m  
90x40x30mm Juniper Green

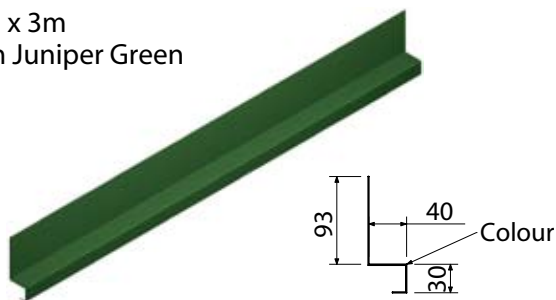

Barge Board x 3m  
115x250mm Juniper Green

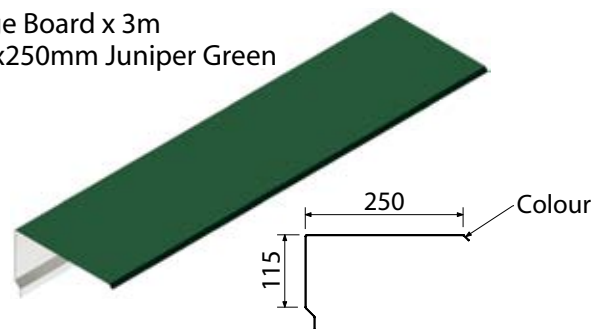

Apron Flashing x 3m  
250x150mm Juniper Green

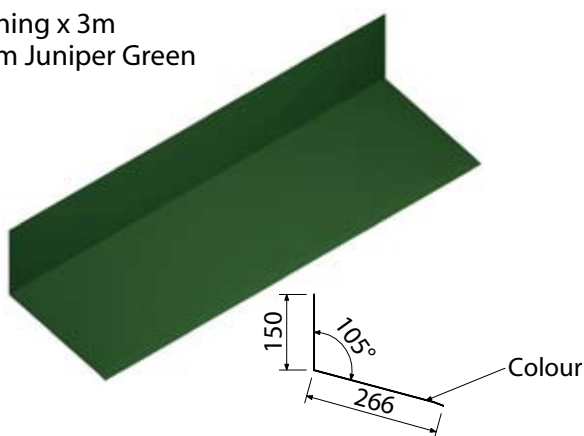

Door Hood Juniper Green x 3m  
75x150x210mm

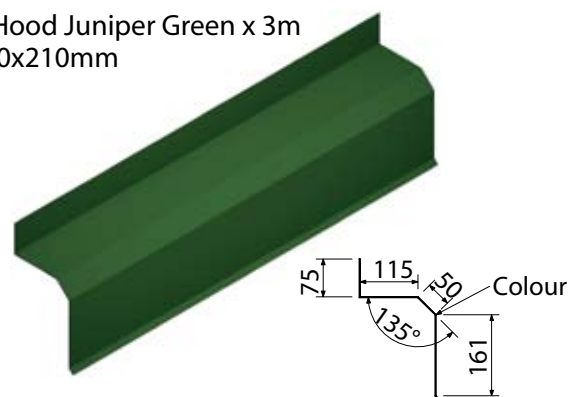

Mono Ridge x 3m  
250x150mm Juniper Green

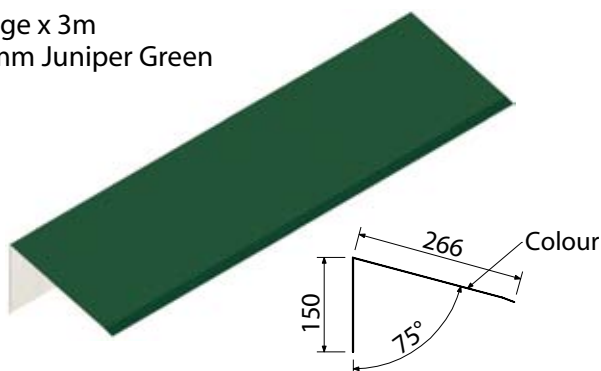

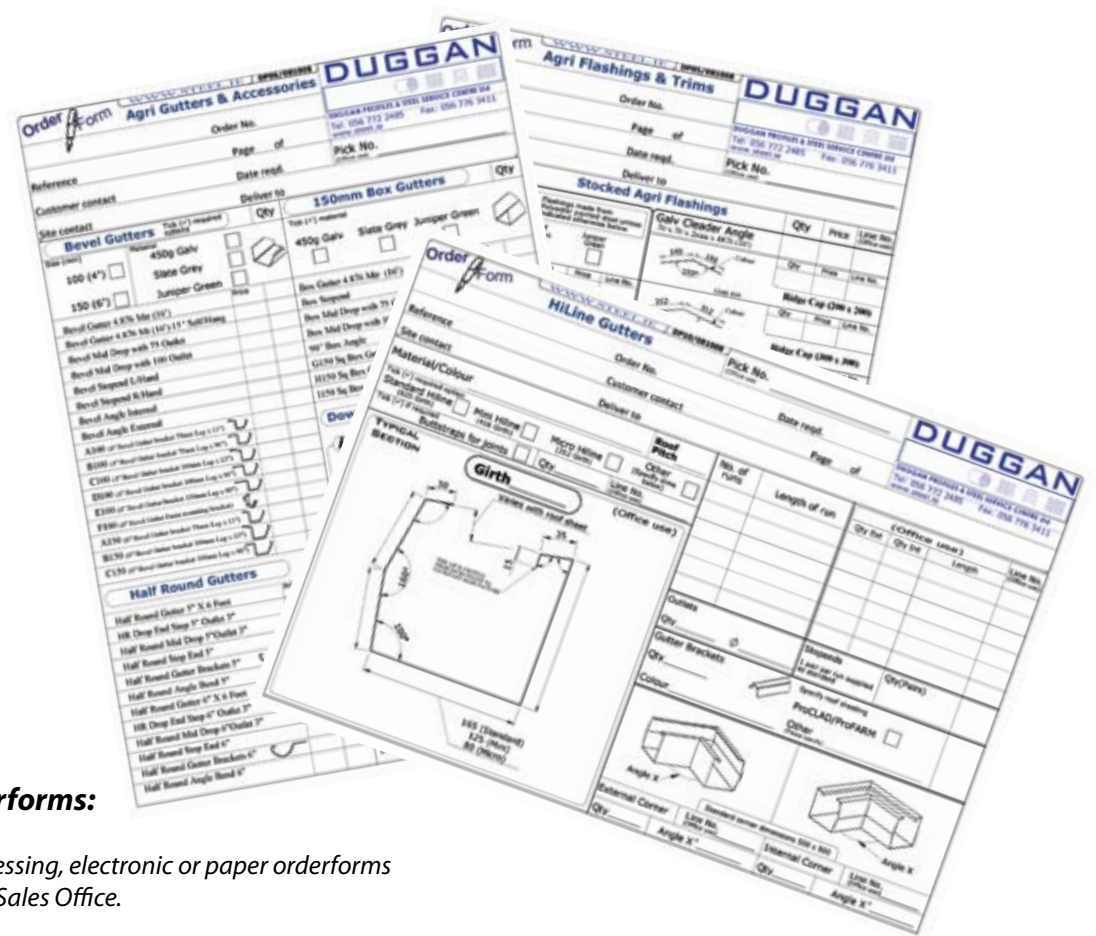

**Request our Orderforms:**

To facilitate order processing, electronic or paper orderforms are available from our Sales Office.

Dublin Road,  
 Kilkenny - Ireland  
 Tel.: +353-56-7722485  
 Fax: +353-56-7763411  
 E-mail: salesdp@steel.ie  
 www.steel.ie



**Do you have the most up to date information?**

The information in this brochure is current at time of publication but subject to change due to product updates, technical advances and the passage of time. Our website provides the most comprehensive, authoritative and up to date source of information on all aspects of the business of the Duggan Steel Group. Check [www.steel.ie](http://www.steel.ie) regularly to ensure you are up to date.



Dublin Road,  
Kilkenny - Ireland  
Tel.: +353-56-7722485  
Fax: +353-56-7763411  
E-mail: [salesdp@steel.ie](mailto:salesdp@steel.ie)  
[www.steel.ie](http://www.steel.ie)

**PRO CLAD**<sup>®</sup>

**PRO UNER**<sup>®</sup>

**PRO COLOR**<sup>®</sup>

**PRO DECK**<sup>®</sup>

**PRO PURLIN**<sup>®</sup>

**PRO LIGHT**<sup>®</sup>

**PRO FARM**<sup>®</sup>

**PRO AIR**<sup>®</sup>

**CORRI FARM**<sup>®</sup>

**CORRI GALV**<sup>®</sup>

**AGRI PURLIN**<sup>®</sup>

**AGRI LIGHT**<sup>®</sup>

DPSSC September 2009  
© copyright Duggan Steel Group Ltd. 2009

[www.steel.ie](http://www.steel.ie)



Please Note: All reasonable care has been taken in the compilation of the information contained within this publication, but Duggan Steel Group Ltd. and its related companies do not accept responsibility for errors or for information which is found to be misleading. Suggestions for, or descriptions of the end use or application of products or methods of working are for information only and Duggan Steel Group Ltd. and its related companies accept no liability in respect thereof. It is the customer's responsibility to ensure that the product is fit for its intended purpose and that the actual conditions of use are suitable. It is also the customer's responsibility to ensure overall compliance with the current Health & Safety and Building Regulations. Dimensions are for illustration purposes only and subject to change. Duggan Steel Group pursues a policy of continuous product development and reserves the right to amend specifications without prior notice. Please refer to our website [www.steel.ie](http://www.steel.ie) for the most up to date information.